

## CRUISE SHIP PIER AND TERMINAL FACILITY SPECIFICATION OVERVIEW

### クルーズ係留施設及びターミナル施設概要

As of 01/01/2023  
2023年1月1日現在

#### ■ Common Information

##### 共通情報

PORT NAME: Port of Tsuruga (Fukui) 港名：敦賀港（福井県）				
LOCATION / ADDRESS: Ote3-17-1, Fukui City, Fukui 910-8580 Japan 住所：福井県福井市大手3-17-1				
PORT CONTACT: Ports and Airports Division, Department of Public Works, Fukui Prefectural Government 連絡先：福井県土木部港湾空港課				
Phone: +81-776-20-0489 電話：0776-20-0489	Fax: +81-776-20-0660 FAX: 0776-20-0660	E-mail: <a href="mailto:kowan@pref.fukui.lg.jp">kowan@pref.fukui.lg.jp</a>		
Mobile phone: N/A 携帯：該当なし	Website: <a href="http://www.pref.fukui.lg.jp/doc/kouwan/tsuruga/tsuruga.html">http://www.pref.fukui.lg.jp/doc/kouwan/tsuruga/tsuruga.html</a>	Other: Tourism Guide <a href="http://www.fuku-e.com/lang/english/index.html">http://www.fuku-e.com/lang/english/index.html</a>		
<b>I . CRUISE SHIP RECORD (OVER THE PAST FIVE YEARS)</b> 寄港実績（過去5年）				
Ship name 船名：	Gross tonnage 総トン数：	LOA 全長：	Draft 喫水：	Maiden call (Year) 初寄港年：
ASUKA II	50,142	240.9	7.8	
PACIFIC VENUS	26,594	183.4	6.52	
DIAMOND PRINCESS	115,875	288.3	8.57	2017

<b>II. CONSULATE OR EMBASSY CONTACT</b>			
<b>大使館または領事館連絡先・所在地</b>			
<b>Nation:</b> 国名 :	<b>Name of consulate or embassy:</b> 大使館または領事館名 :	<b>Phone:</b> 電話番号 :	<b>Place:</b> 所在地 :
Australia	Australian Embassy in Japan	+81-3-5232-4111	Tokyo
Canada	Embassy of Canada in Japan	+81-3-5412-6200	Tokyo
China	Consulate-General of the People's Republic of China in Nagoya	+81-52-932-1098	Nagoya City
Germany	Consulate-General of the Federal Republic of Germany in Osaka-Kobe	+81-6-6440-5070	Osaka City
France	Consulate-General of France in Kyoto	+81-75-761-2988	Kyoto City
Italy	Embassy of Italy in Japan	+81-3-3453-5291	Tokyo
Korea	Consulate-General of the Republic of Korea in Niigata	+81-25-255-5555	Niigata City
United Kingdom	British Consulate-General in Osaka	+81-6-6120-5600	Osaka City
United States of America	Consulate-General of the United States of America in Osaka-Kobe	+81-6-6315-5900	Osaka City

## ■ Wharf (Pier) Information

### 埠頭別情報

Wharf (Pier) name: Mariyama Minami Wharf ふ頭名：鞠山南		
<b>III. PHYSICAL CONSIDERATIONS</b> 物理的留意事項		
1. Berth 岸壁	Length / Water depth 延長/水深	①Mariyama Minami      280m / -14m
	Height of the pier above MLW or chart datum (平均干潮位又は海図基準 からの) 岸壁の高さ	①Mariyama Minami      2.50m
	Pier depth (distance to the closest obstruction behind the pier edge) 岸壁の幅 (岸壁の端から背 後障害物までの距離)	①Mariyama Minami      300m
	Minimum depth across the berth 岸壁の最低水深	①Mariyama Minami      -14m
	Fender bar 防舷材 Absorbed energy / number of the fender bars 吸収エネルギー/本数	① Mariyama Minami      43.6 tf・m / 19
	Bollard 係船柱 Specification / number of the bollards スペック/本数 z	①Mariyama Minami      102t / 10 , 153t / 2
2. Channel 航路	Width / water depth 幅/水深	more than 800m / more than -12m
3. Turning basin (diameter) 回頭泊地 (直径)		The minimum diameter of turning basin is 1200m.
4. Clearance 高さ制限		No limit
5. Maximum tidal range / max currents 最大潮差/最大潮流		(tidal range) 0.48m/ Tidal currents are weak.
6. Wind & weather conditions / tides by season 風及び季節による天候/潮汐の変化		

<b>IV. LANDSIDE FACILITIES</b>		
陸上施設		
1. Terminal ターミナル等	Terminal Availability ターミナルの有無	No
	Shelter or facilities to shelter from rain (無い場合) 雨よけ施 設の有無	No
	Boarding Bridge ボーディングブリッジ	No
2. Shore gangway ギヤングウェイ		No
3. Pay phone 公衆電話		No
4. Restroom / washroom トイレ		Available(temporary)
5. Vending machine / kiosk 自動販売機・売店		Available(temporary)
6. Need to arrange shuttles to downtown? 市街地へシャトルバスが必要か		Yes
7. Distance and time to downtown? 市街地までの距離・時間		4km / 5 min by car
8. Distance and time to primary sightseeing area 主要観光地までの距離・時間		Kehi Jingu Shrine: 3Km/5 min by car
<b>V. CUSTOMS AND IMMIGRATION</b>		
税関及び入国管理		
1. Availability of CIQ services and facilities CIQ の有無	Permanent 常設	No
	Temporary 仮設 (船上を含む)	Yes
2. Secure electronic access 自動化出入国ゲートの有無		No
<b>VI. WORKING HOURS</b>		
サービス提供時間		
1. Pilotage パイロット		24hrs (Prior consultation required)
2. Tuggage タグ		24hrs (Prior consultation required)
3. Line handling 綱とり		24hrs (Prior consultation required)
4. Other (pls specify) その他		
<b>VII. SECURITY</b>		
セキュリティ		
1. ISPS certified? ISPS の認定有無		Yes

<b>VIII. TRANSPORTATION</b> 交通機関		
1. Parking for tour buses (number of buses) 観光バス待機所 (駐車台数)		Available(temporary)
2. Parking for private cars (number of cars) 自家用車駐車場 (駐車台数)		Not available
3. Parking for taxis (number of taxis) タクシープール (駐車台数)		Available(temporary)
4. Name of the nearest airport from the pier ふ頭から最も近い空港の名称		Komatsu Airport CHUBU CENTRAIR International Airport
5. Time from the pier to the airport by car ふ頭から空港までの車での移動時間		90 min(Komatsu Airport) 130 min(CHUBU CENTRAIR International Airport)
6. Name of the nearest rail station from the pier ふ頭から最も近い鉄道駅の名称		JR Tsuruga Station
7. Time from the pier to the rail station by car ふ頭から鉄道駅までの車での移動時間		10 min
<b>IX. TERMINAL SERVICE</b> ターミナル内のサービス		
1. Wi-Fi service Wi-Fi サービス		Available(temporary)
2. Postal & delivery service 郵便・宅配便サービス		No
3. Foreign exchange 外貨両替所	Availability 両替所の有無	Available(temporary)
	Kinds of currencies 取り扱い貨幣の種類	Negotiable
	Business hours・days 営業時間・営業日	Negotiable
4. Tourist information 観光案内所	Availability 観光案内所の有無	Available(temporary)
	Language 対応言語	Negotiable
	Business hours・days 営業時間・営業日	Negotiable

X. REFERENCE INFORMATION

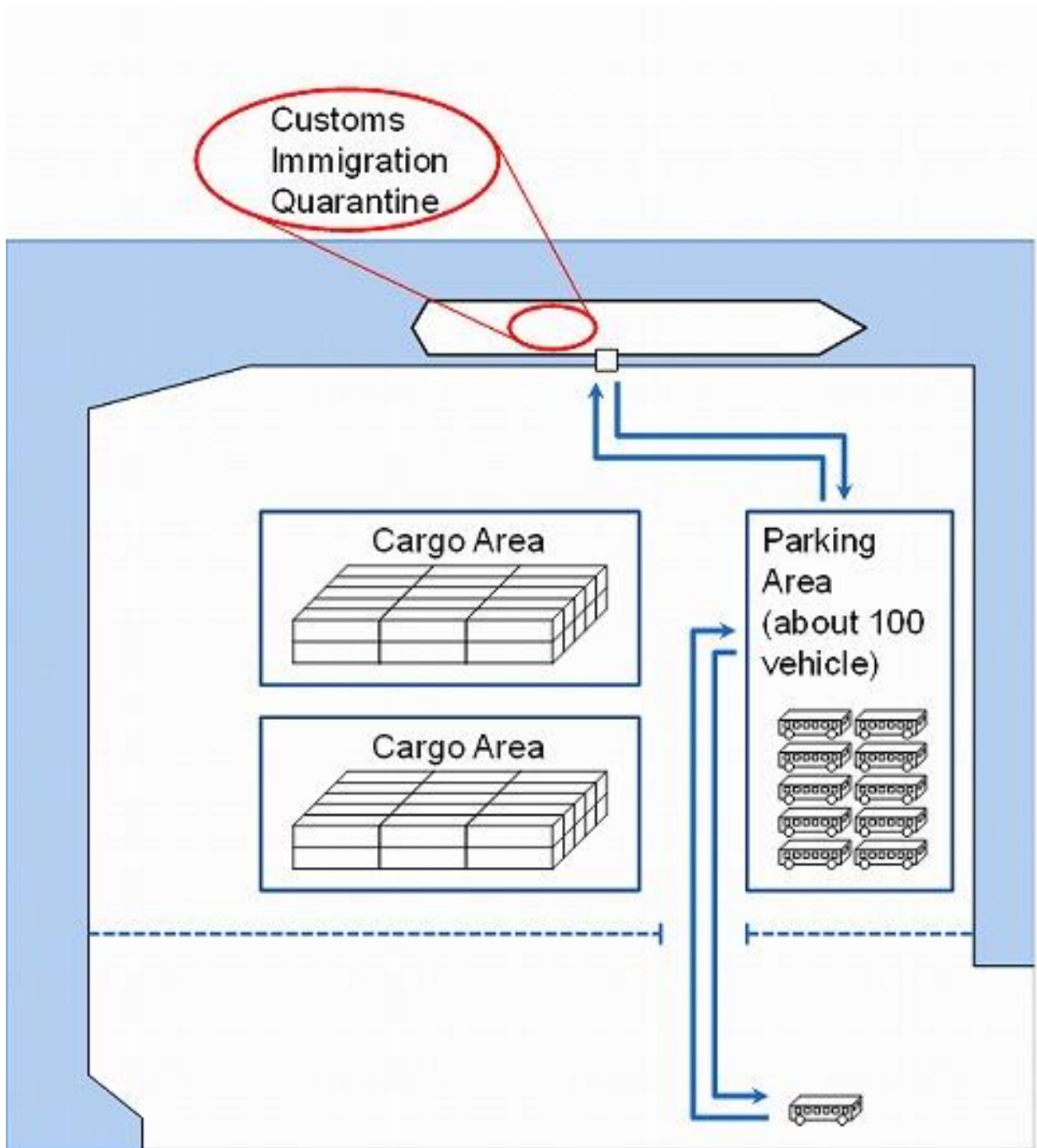
参考情報

Wharf position figure

ふ頭位置図

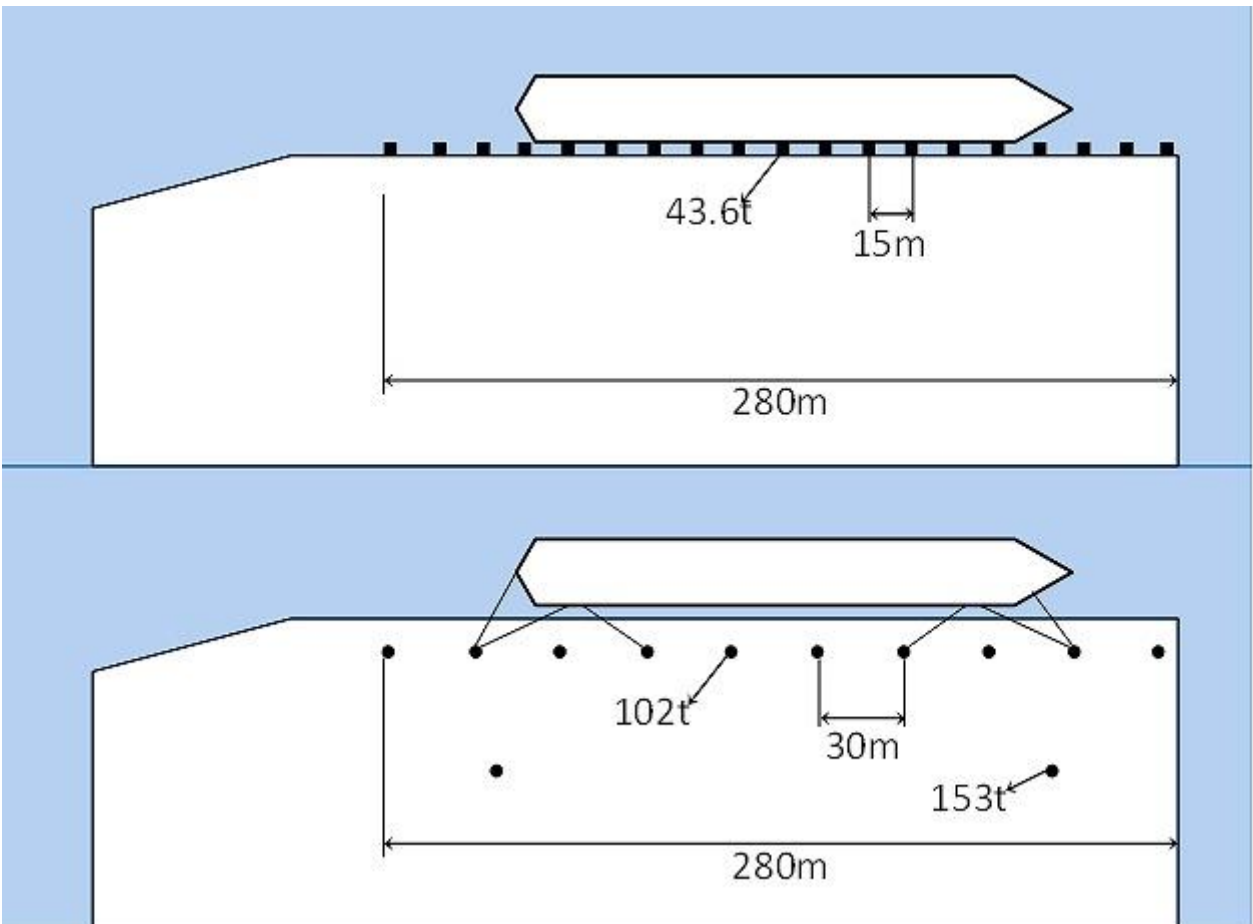


Figure of the terminal placement and passenger line of flow  
ターミナル配置図と受入動線





The details of a fender bar and bollard  
防舷材と係船柱の詳細





## ■ Wharf (Pier) Information

### 埠頭別情報

Wharf (Pier) name: Mariyama Kita Wharf ふ頭名：鞠山北		
<b>III. PHYSICAL CONSIDERATIONS</b> 物理的留意事項		
1. Berth 岸壁	Length / Water depth 延長/水深	①Mariyama Kita      480m / -12m
	Height of the pier above MLW or chart datum (平均干潮位又は海図基準 からの) 岸壁の高さ	①Mariyama Kita      2.50m
	Pier depth (distance to the closest obstruction behind the pier edge) 岸壁の幅 (岸壁の端から背 後障害物までの距離)	①Mariyama Kita      20m
	Minimum depth across the berth 岸壁の最低水深	①Mariyama Kita      -12m
	Fender bar 防舷材 Absorbed energy / number of the fender bars 吸収エネルギー/本数	① Mariyama Kita      18.9tTm / 19 26.1 tTm /5 46.7 tTm /11
	Bollard 係船柱 Specification / number of the bollards スペック/本数	① Mariyama Kita      70t / 16 , 100t / 4 , 150t / 4 153t /4
2. Channel 航路	Width / water depth 幅/水深	more than 800m / more than -12m
3. Turning basin (diameter) 回頭泊地 (直径)		The minimum diameter of turning basin is 1200m.
4. Clearance 高さ制限		No limit
5. Maximum tidal range / max currents 最大潮差/最大潮流		(tidal range) 0.48m/ Tidal currents are weak.
6. Wind & weather conditions / tides by season 風及び季節による天候/潮汐の変化		

<b>IV. LANDSIDE FACILITIES</b>		
陸上施設		
1. Terminal ターミナル等	Terminal Availability ターミナルの有無	No
	Shelter or facilities to shelter from rain (無い場合) 雨よけ施 設の有無	No
	Boarding Bridge ボーディングブリッジ	No
2. Shore gangway ギヤングウェイ		No
3. Pay phone 公衆電話		No
4. Restroom / washroom トイレ		Available(temporary)
5. Vending machine / kiosk 自動販売機・売店		Available(temporary)
6. Need to arrange shuttles to downtown? 市街地へシャトルバスが必要か		Yes
7. Distance and time to downtown? 市街地までの距離・時間		4km / 5 min by car
8. Distance and time to primary sightseeing area 主要観光地までの距離・時間		Kehi Jingu Shrine: 3Km/5 min by car
<b>V. CUSTOMS AND IMMIGRATION</b>		
税関及び入国管理		
1. Availability of CIQ services and facilities CIQの有無	Permanent 常設	No
	Temporary 仮設 (船上を含む)	Yes
2. Secure electronic access 自動化出入国ゲートの有無		No
<b>VI. WORKING HOURS</b>		
サービス提供時間		
1. Pilotage パイロット		24hrs (Prior consultation required)
2. Tuggage タグ		24hrs (Prior consultation required)
3. Line handling 綱とり		24hrs (Prior consultation required)
4. Other (pls specify) その他		
<b>VII. SECURITY</b>		
セキュリティ		
1. ISPS certified? ISPSの認定有無		Yes

<b>VIII. TRANSPORTATION</b> 交通機関		
1. Parking for tour buses (number of buses) 観光バス待機所 (駐車台数)		Available(temporary)
2. Parking for private cars (number of cars) 自家用車駐車場 (駐車台数)		Not available
3. Parking for taxis (number of taxis) タクシープール (駐車台数)		Available(temporary)
4. Name of the nearest airport from the pier ふ頭から最も近い空港の名称		Komatsu Airport CHUBU CENTRAIR International Airport
5. Time from the pier to the airport by car ふ頭から空港までの車での移動時間		90 min(Komatsu Airport) 130 min(CHUBU CENTRAIR International Airport)
6. Name of the nearest rail station from the pier ふ頭から最も近い鉄道駅の名称		JR Tsuruga Station
7. Time from the pier to the rail station by car ふ頭から鉄道駅までの車での移動時間		10 min
<b>IX. TERMINAL SERVICE</b> ターミナル内のサービス		
1. Wi-Fi service Wi-Fi サービス		Available(temporary)
2. Postal & delivery service 郵便・宅配便サービス		No
3. Foreign exchange 外貨両替所	Availability 両替所の有無	Available(temporary)
	Kinds of currencies 取り扱い貨幣の種類	Negotiable
	Business hours・days 営業時間・営業日	Negotiable
4. Tourist information 観光案内所	Availability 観光案内所の有無	Available(temporary)
	Language 対応言語	Negotiable
	Business hours・days 営業時間・営業日	Negotiable

X. REFERENCE INFORMATION

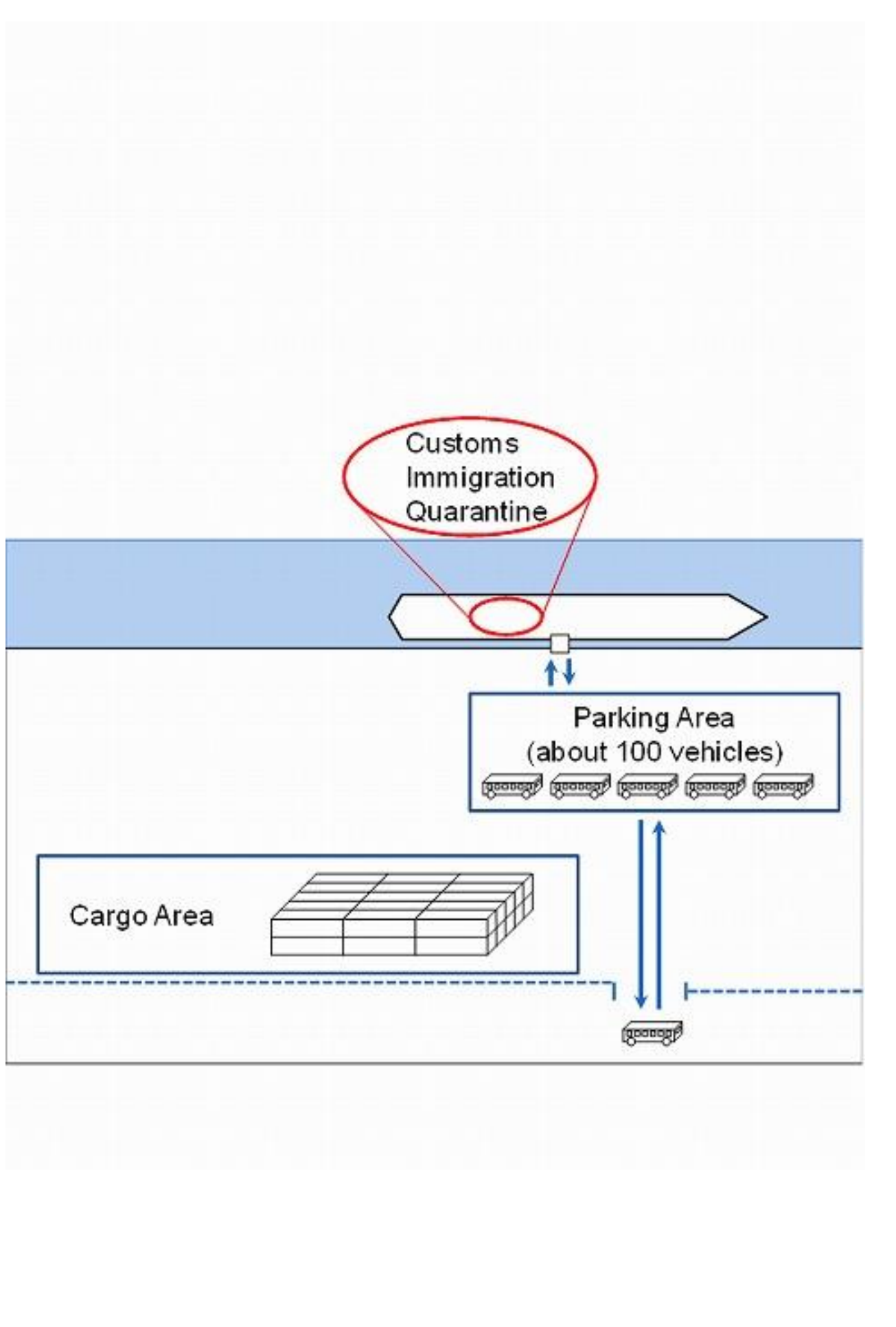
参考情報

Wharf position figure

ふ頭位置図



Figure of the terminal placement and passenger line of flow  
ターミナル配置図と受入動線



The details of a fender bar and bollard  
防舷材と係船柱の詳細

